

## Features

- Single Conventional Zone Input
- Apollo XP95 & Discovery protocol
- Supports up to 40 conventional detectors
- Remote LED Output
- Short Circuit Isolation
- Programmable EOL (3K3Ω, 6K2Ω or 10uF)

## Description

AMPAC's Loop Powered Zone Interface Device (LZID) is designed to connect to the analogue loops in any of AMPAC's addressable range of fire alarm control panels (FACP's).

The LZID supports the Apollo XP95 & Discovery protocol and provides a single conventional zone input and a remote LED output to indicate an Alarm.

The LZID is available in a DIN rail chassis or alternatively housed in an IP41 enclosure. The device is easy to install and provides access for termination of field wiring up to 2.5mm<sup>2</sup>.

The Conventional Zone input circuit can accommodate up to 40 conventional detectors. (Orbis, Series 60/65, Hochiki and NZ Conventional Heat detector range)

The LZID can be programmed to function in any one of the following modes:

- Normal (latching)
- Non-latching
- Self Reset
- Dependency A, B and C (LoopSense only)
- Investigation (LoopSense only)
- Alarm Verification Facility (AVF) (FireFinder only)

The Conventional Zone input has a programmable End of Line (EOL) feature that allows for either a 3K3Ω or 6K2Ω resistor value to be used. Alternatively the EOL can be a 10uF capacitor which is required to support the head removal feature when the appropriate diode bases are used on the conventional circuits. The EOL value for the zone is set by an onboard DIP switch.

The LZID responds to Loop addresses from 1 – 126. The Loop address is set by the onboard DIP switches.

The LZID is capable of reporting the following zone conditions:

- Normal Condition
- Open Circuit condition
- Short Circuit condition
- Alarm Condition

The LZID has an onboard Short Circuit Isolator (SCI) function between the two negative loop connectors.

The LZID has three onboard LED's for indicating Alarm (Red), Poll/SCI (Green) and Fault (Yellow) conditions.



Figure 1 Loop Powered Zone Interface Device (DIN)



Figure 2 Loop Powered Zone Interface Device (Enclosed)

## Specifications

<b>Operating Voltage</b>	16Vdc – 27Vdc		
<b>Zone Voltage (Loop Voltage ≥21V)</b>	17 – 22Vdc		
<b>End Of Line Values</b>	3K3Ω	6K2Ω	10uF
<b>Quiescent Current (EOL Fitted, Zone Voltage = 22V and no detector load)</b>	12mA	9mA	6mA
<b>Alarm Current (remote LED not fitted)</b>	28.5mA	28.5mA	28.5mA
<b>Alarm Current (remote LED fitted)</b>	32mA	32mA	32mA
<b>No LZID's / Loop</b>	12 x 250mA Loop 24 x 500mA Loop		
<b>No. Detectors / Zone</b>	40 Max		
<b>Operating temperature</b>	0°C to +70°C		
<b>Dimensions DIN Mount</b>	98mm (L) x 72.5mm (W) x 40mm (D)		
<b>Enclosed / Boxed</b>	200mm (L) x 150mm (W) x 60mm (D)		
<b>Weight DIN Mount</b>	140g		
<b>Enclosed / Boxed</b>	460g		

### Item Numbers

4210-0004	Loop Power ZID DIN Mount
4210-0005	Loop Power ZID Enclosed

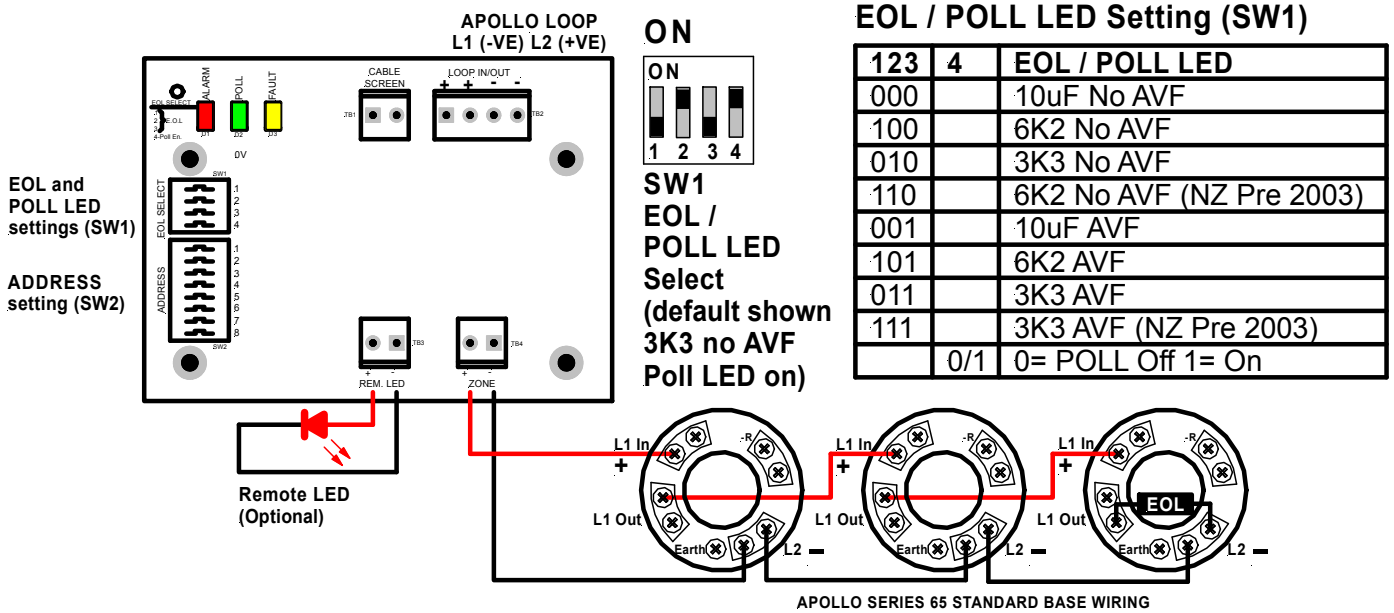

Figure 3 LZID APOLLO Series 65 General Wiring Diagram Example

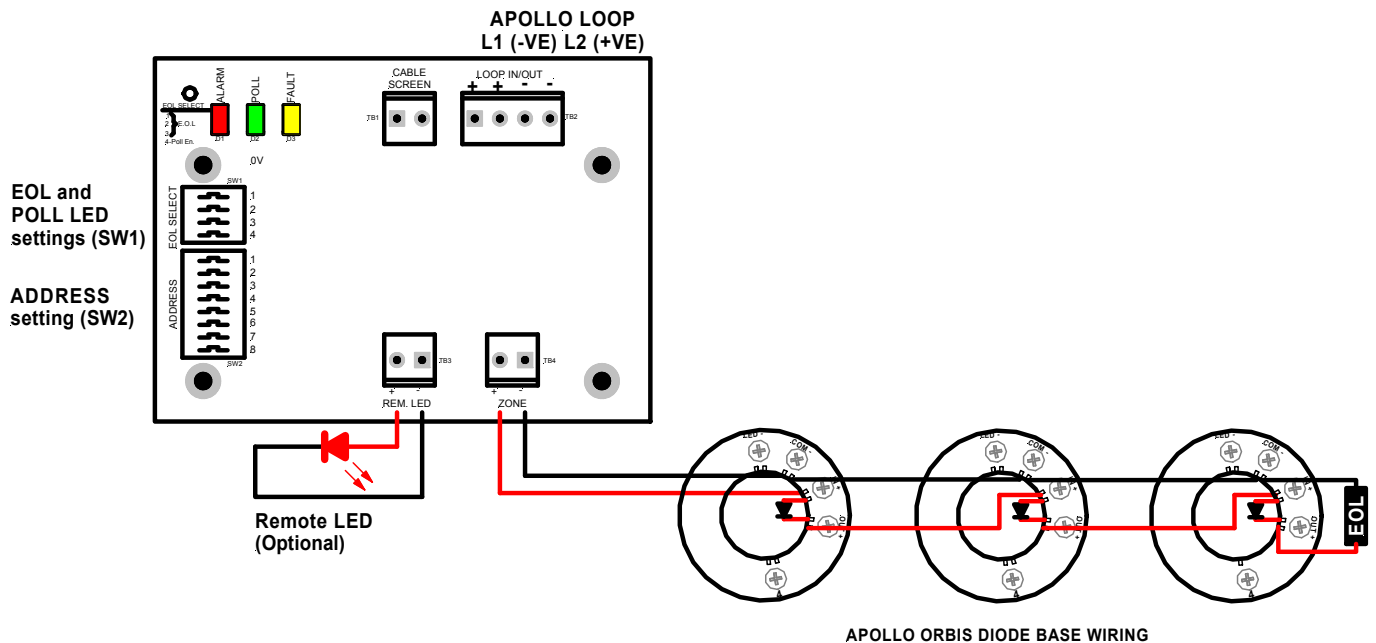

Figure 4 LZID APOLLO Orbis General Wiring Diode Base Example